

BR4/BR4-A

Link con freno singolo

Single brake swing damper **EN** | **FR** Amortisseur pivotant unique
 Einzelner Pendeldämpfer **DE** | **ES** Amortiguador giratorio simple

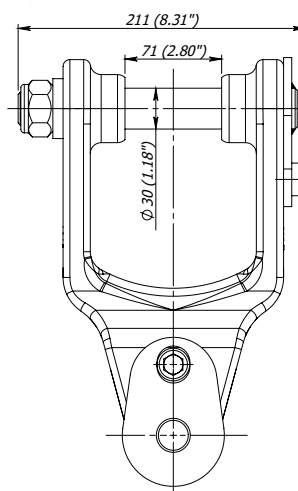
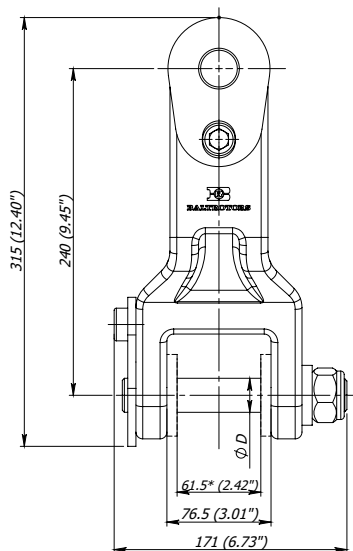
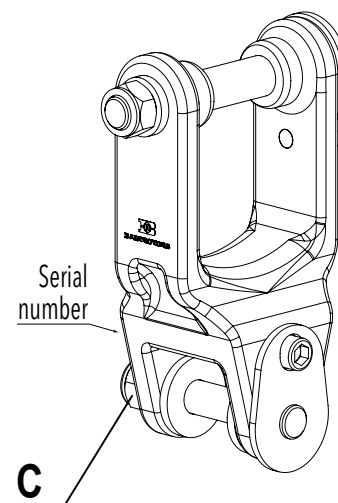

Diametro del perno
 Pin diameter

BR4 ØD (mm)	25 (0.98")
BR4-A ØD (mm)	30 (1.18")



Max. Load - 5.5 ton (55 kN) (12364 lbf)
 Weight - 11.7±0.5 kg (25.8±1.1 lb)

Pin locking nut (C) has to be tightened with a torque of 120 Nm (89 lb ft).

* only by request for rotator GR 30